

EUROPEAN ORGANIZATION FOR NUCLEAR RESEARCH

DIRAC note 2005-07  
28 April 2005

**Existing and new VH, HH, PR**  
(dimensions)

A.Kuptsov

GENEVA  
2005

### **Abstract**

Present report describes dimensions of the existing and new DIRAC vertical hodoscopes (VH), horizontal hodoscopes (HH) and preshower (PR). Dimensions of the new VH, HH and PR were estimated using particle tracing in magnetic field and simulation.

# Contents

<b>1</b>	<b>Particle tracing and simulation</b>	<b>2</b>
<b>2</b>	<b>Vertical hodoscopes</b>	<b>3</b>
2.1	Existing VHs . . . . .	3
2.2	New VHs . . . . .	8
<b>3</b>	<b>Horizontal hodoscopes</b>	<b>12</b>
3.1	Existing HHs . . . . .	12
3.2	New HHs . . . . .	17
<b>4</b>	<b>Preshowers</b>	<b>22</b>
4.1	Existing PR . . . . .	22
4.2	New PR . . . . .	29

# 1 Particle tracing and simulation

Pions and kaons from  $A_{\pi K}$  atom breakup were traced through the spectrometer magnet and downstream detectors using curvature radii of particles in magnetic field. After that  $\pi K$  pairs are retained which are detected by all the drift chambers. Other detectors are ignored.

Simulation of pions and kaons from  $A_{\pi K}$  breakup was also performed (O.Gortchakov). Angular aperture of the secondary particle channel, pion and kaon decays and pion and kaon detection by DC were taken into account. Other detectors were ignored.

Pion and kaon space distributions from simulation were transformed to AutoCAD and were put together with pion and kaon trajectories from tracing. Tracing and simulation agree well.

Dimensions of VH, HH, PR and additions to them are available in table 1.

Table 1: *Horizontal dimensions of VH, HH, PR and additions to them.*

Det	Dist	$W_D$	$W_\pi$	$W_K$	$\Delta_\pi$	$\Delta_K$
VH	3275	1302	1285	364	58	48
HH	3410	1307	1338	380	91	81
PR	7056	2800	2740	789	270	274

Explanations to the table 1:

Det: detectors.

Dist: distance in mm from the magnet centre to the VH, HH and PR centres.

$W_D$ : width of detectors in mm.

$W_\pi$ : width of pion beam in mm.

$W_K$ : width of kaon beam in mm.

$\Delta_\pi$ : addition to detectors for pion detection.

$\Delta_K$ : addition to detectors for kaon detection.

## 2 Vertical hodoscopes

### 2.1 Existing VHS

Figs. 1, 2, 3, 4, 5.

Horizontal dimension of VH is 1302 mm. VH consists of 18 scintillation slabs of 70 mm in width which were separated at the beginning by 2.5 mm gaps. Later the gaps were decreased. Probably these gaps now are equal to 1 mm each. Then the VH width now may be is 1277 mm. But I will use known me value 1302 mm.

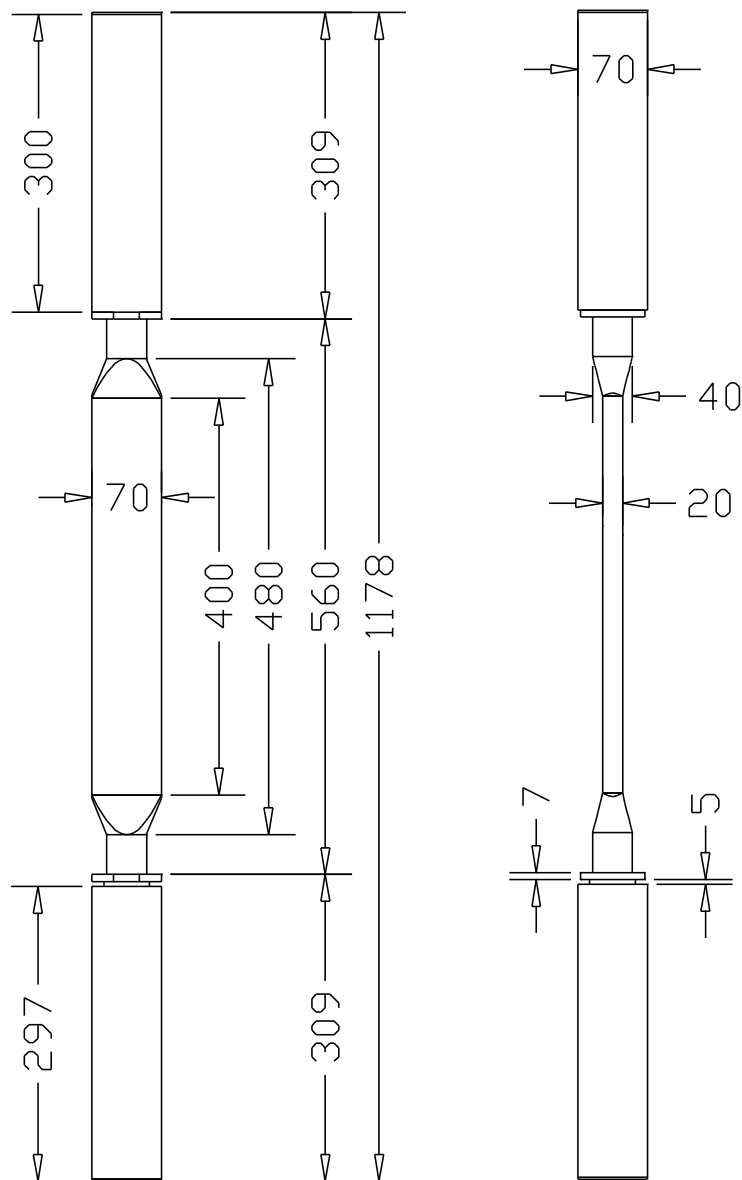

Figure 1: *Existing VH: scintillation counter.*

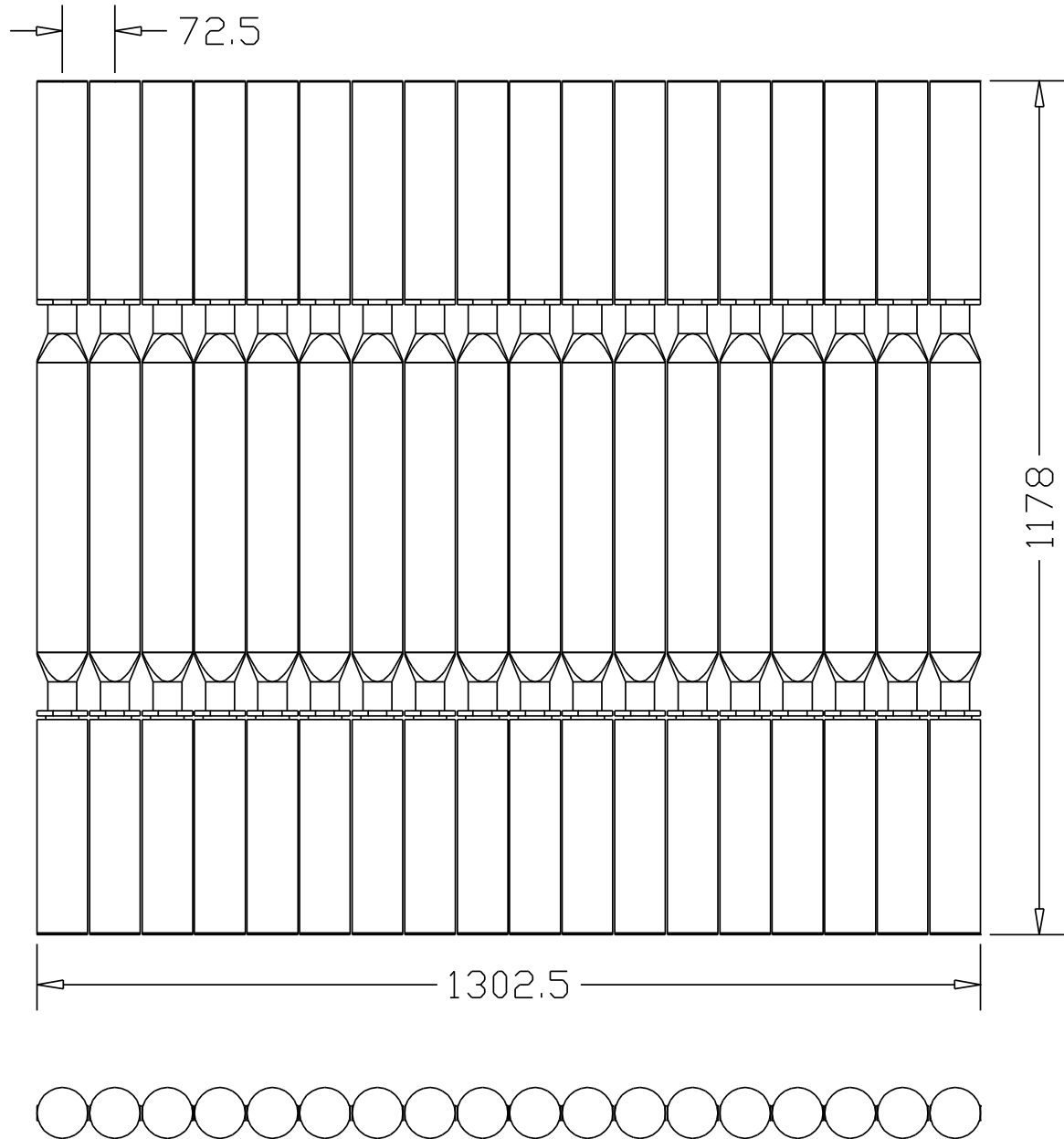

Figure 2: Existing VH: scintillators and PMs.

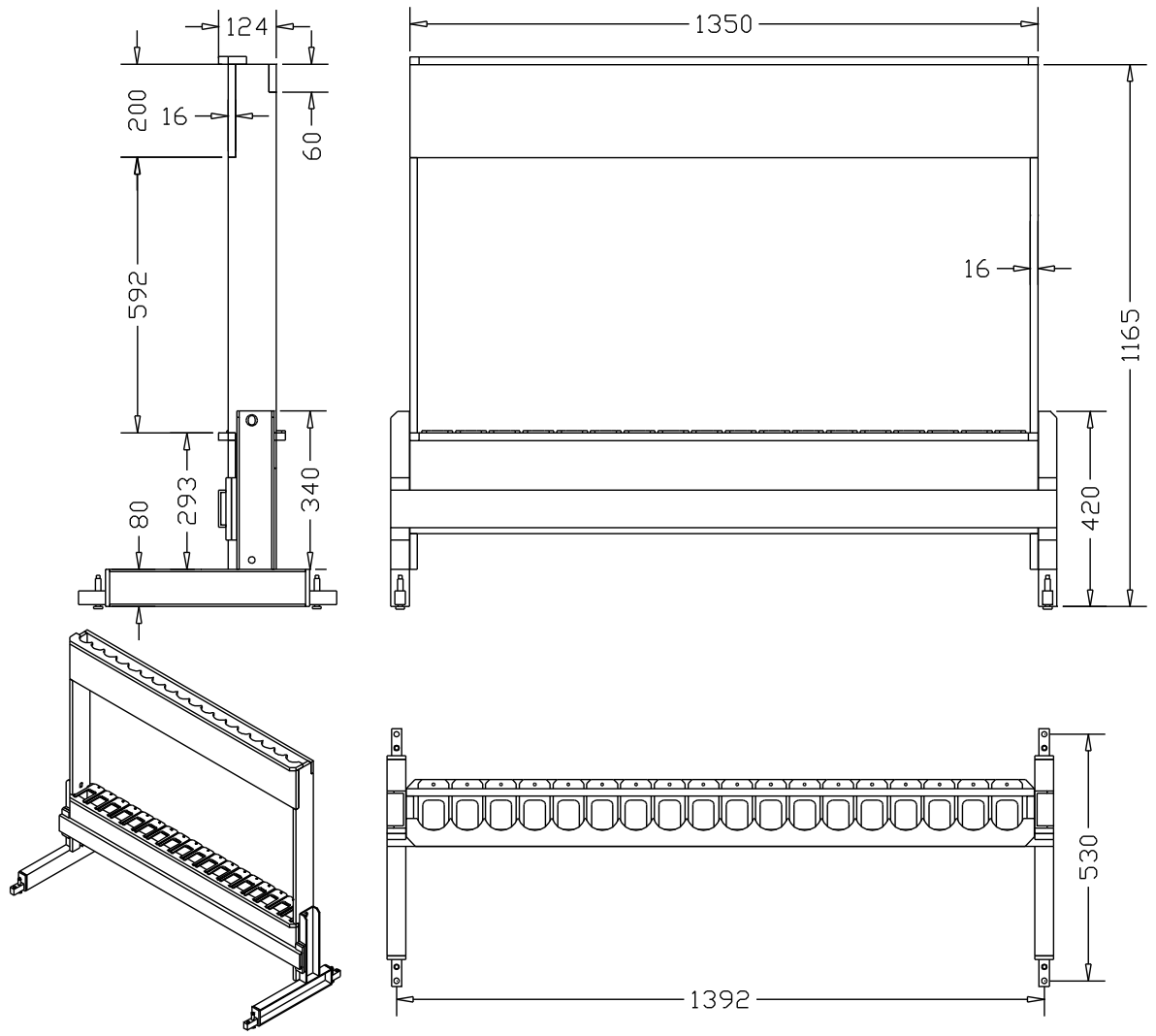

Figure 3: Existing VH: support.

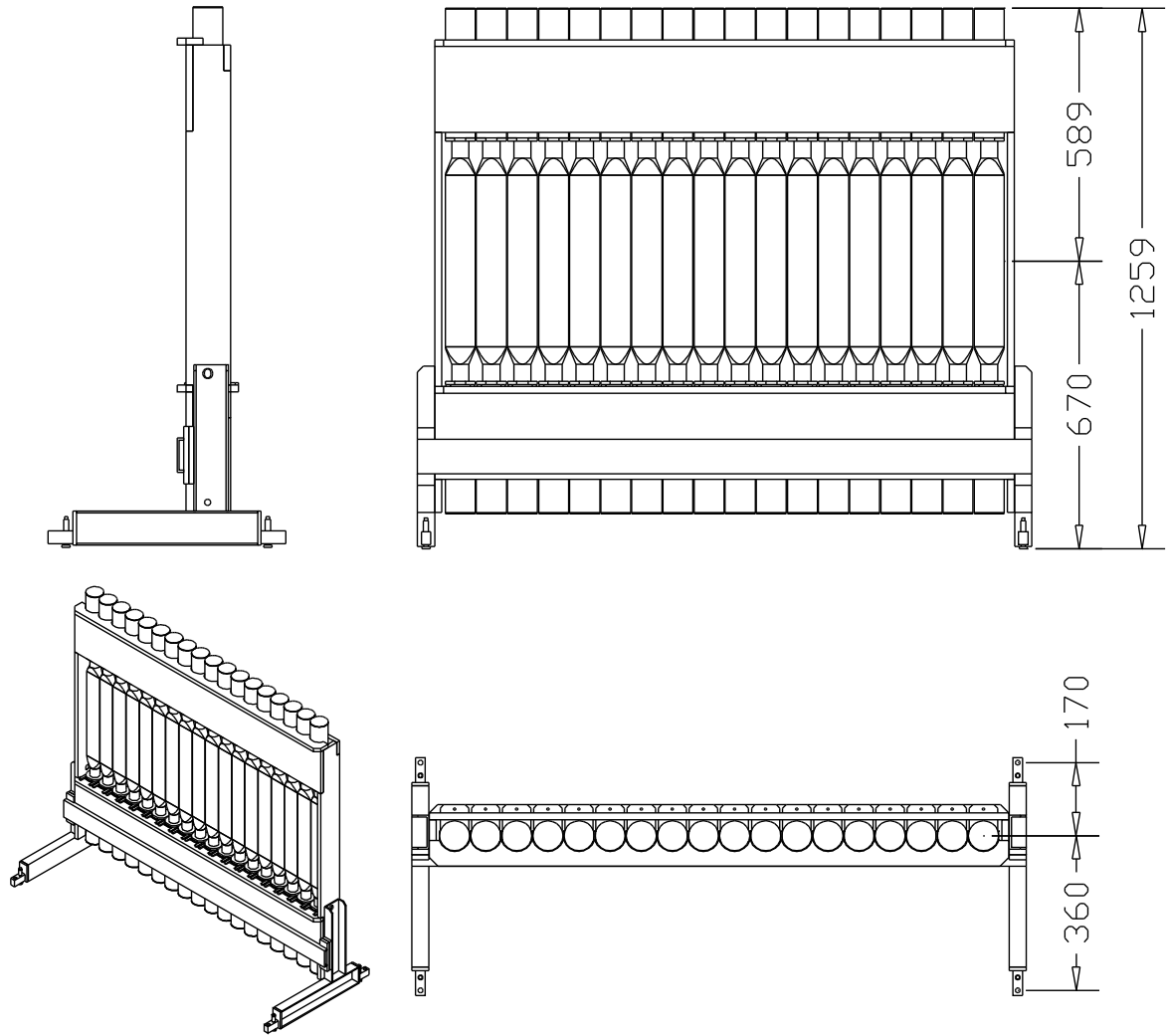

Figure 4: *Existing VH.*



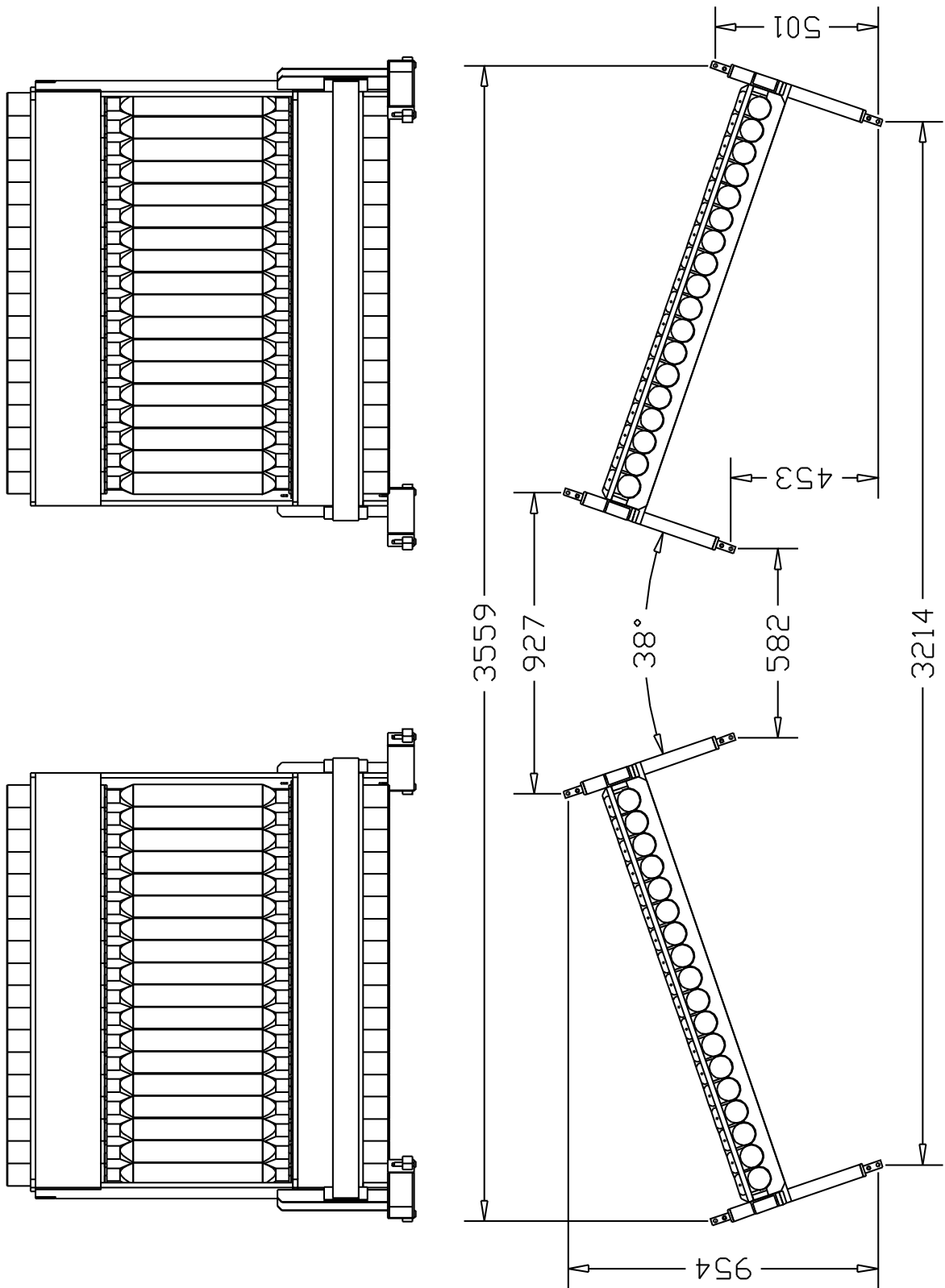

Figure 5: *Existing VHs.*

## 2.2 New VHs

Figs. 6, 7, 8, 9.

If we add two slabs of 70 mm in width to the existing VH (4 slabs in total) it will be enough for  $A_{\pi K}$  detection without losses when  $\pi$  and  $K$  are detected by DC.

The simplest way to modify the VH support is to cut Al plates in the centre and to weld spacers to them (fig. 7). It is also necessary to manufacture additional 4 forks to fix new modules.

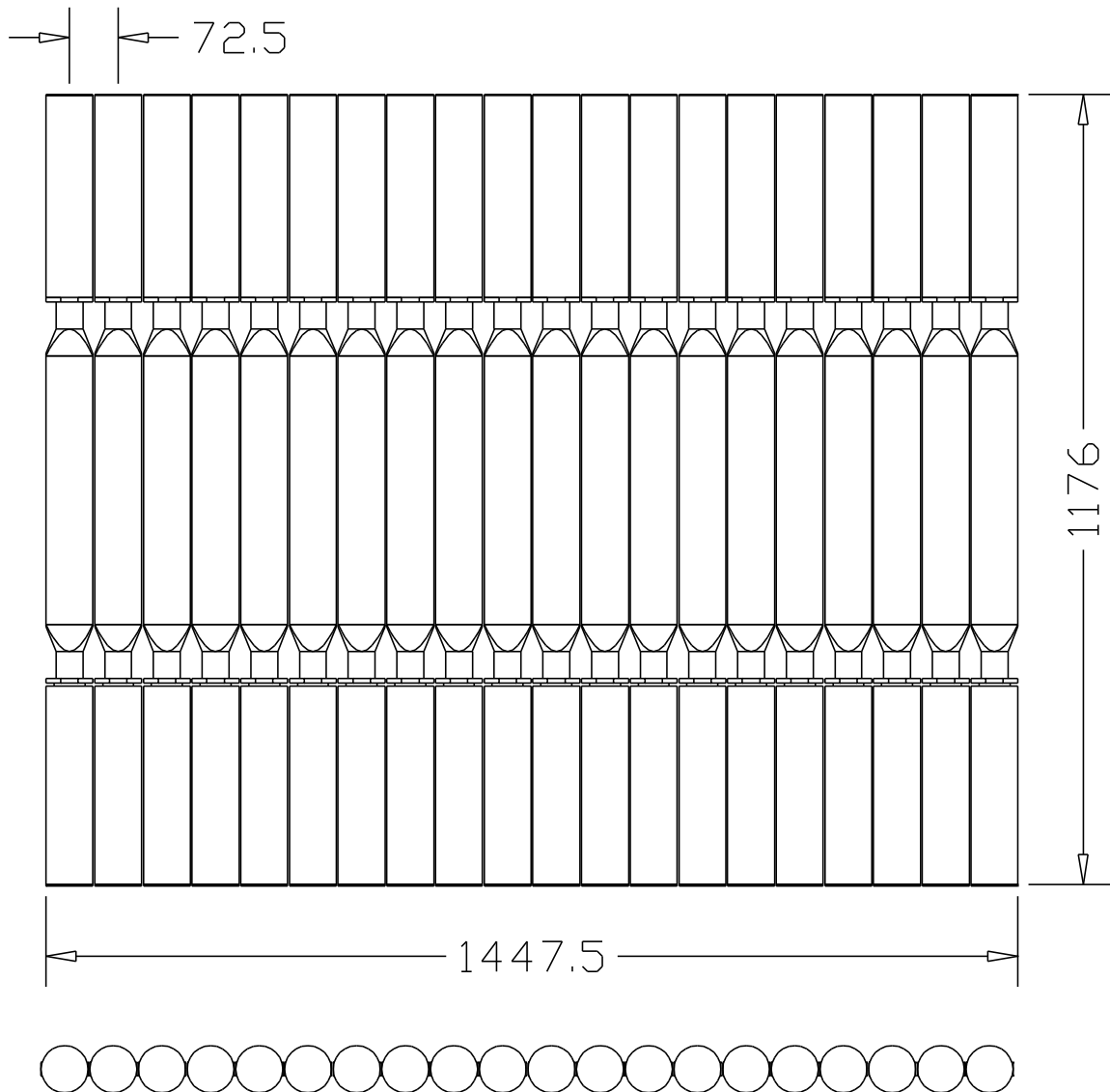

Figure 6: *New VH: scintillators and PMs.*

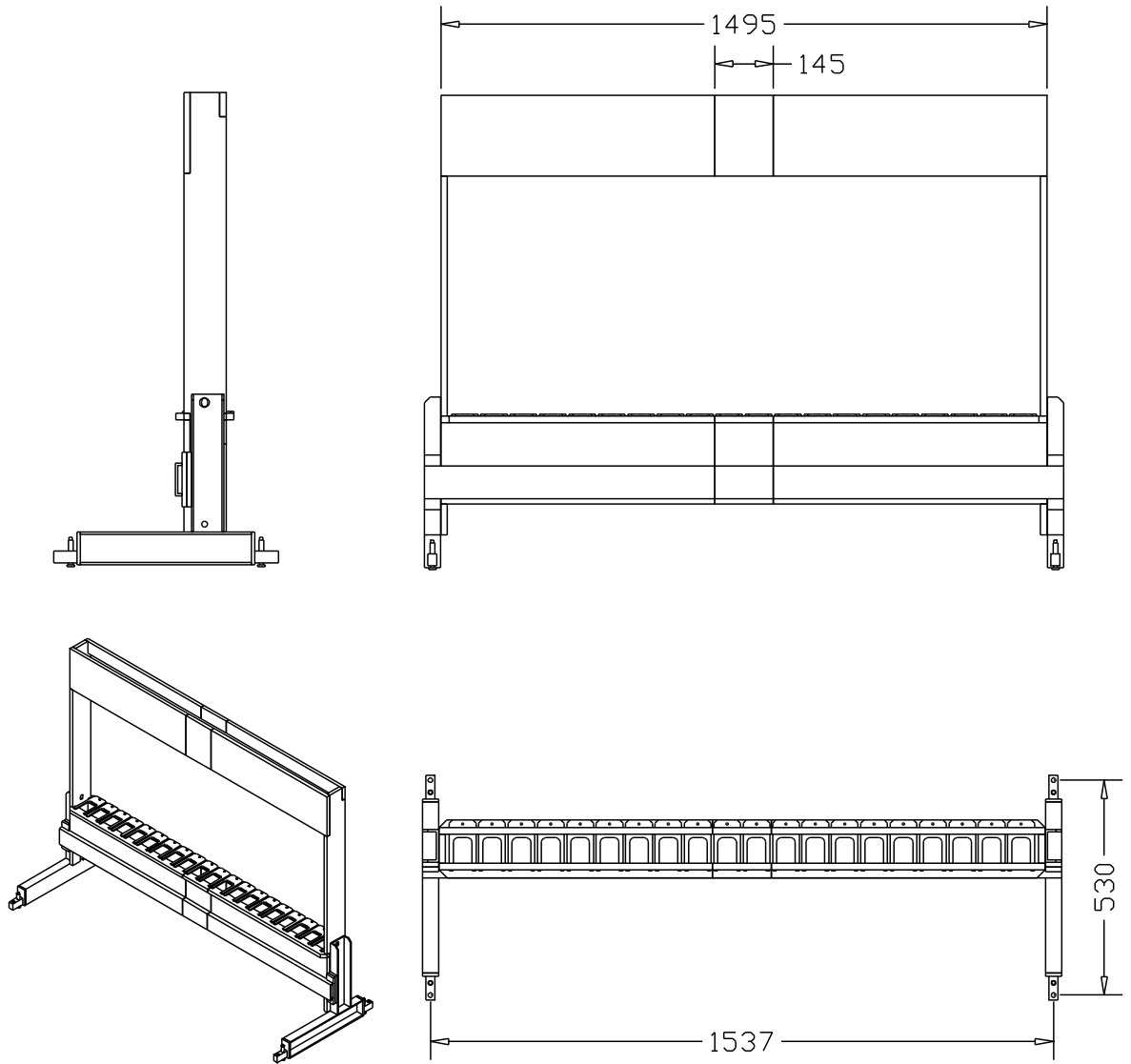

Figure 7: *New VH: support.*

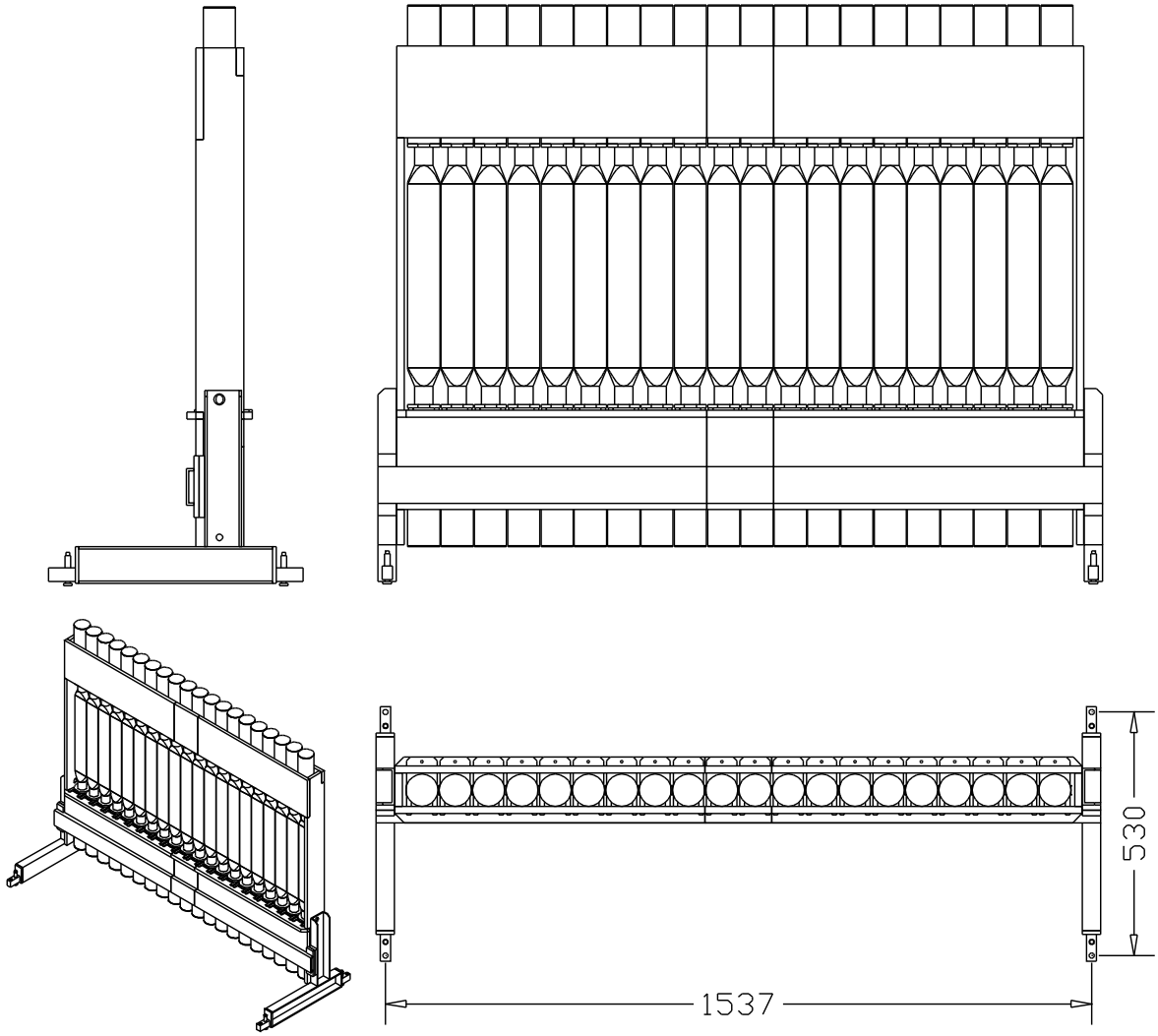

Figure 8: *New VH.*

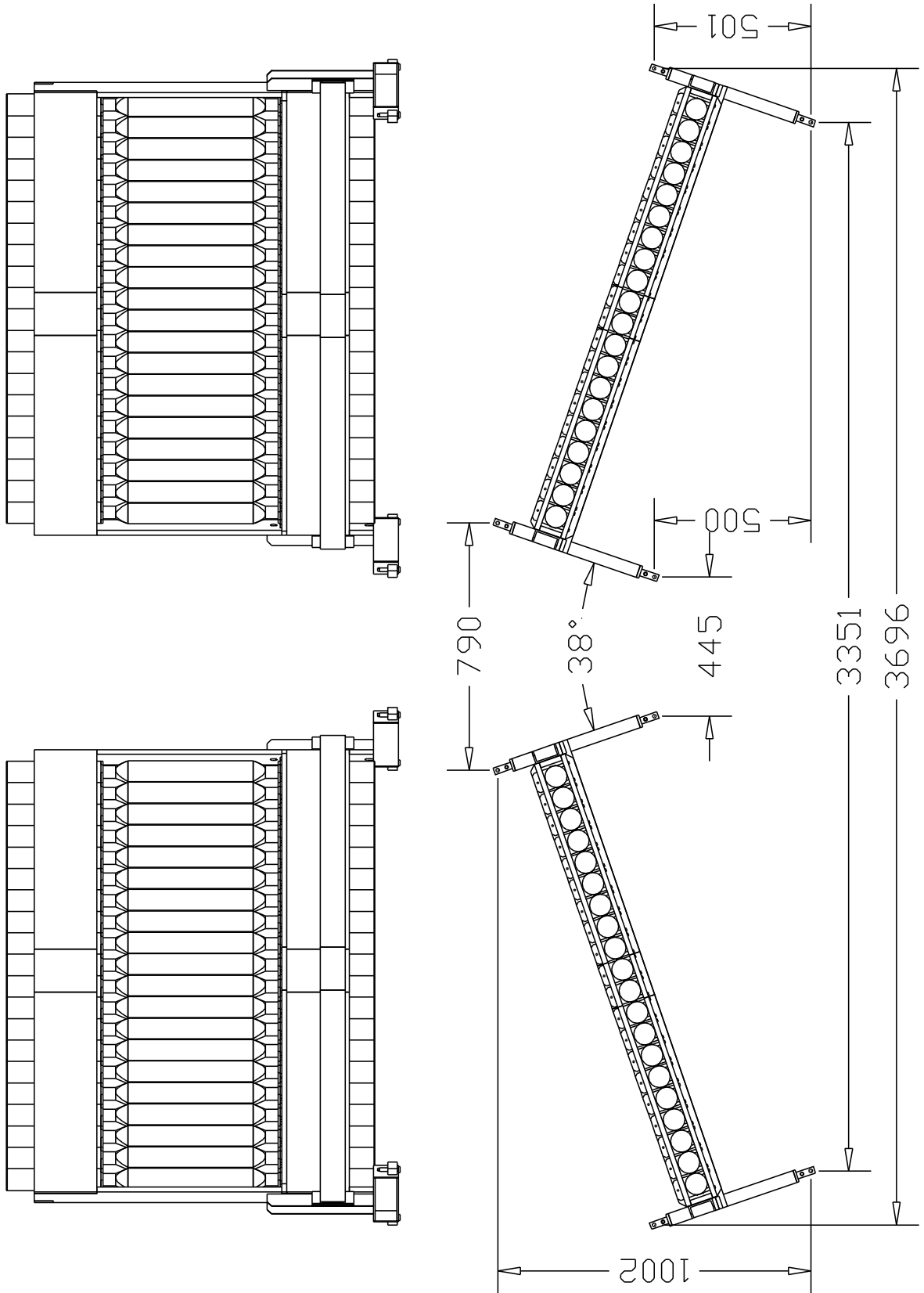

Figure 9: *New VHs.*

### 3 Horizontal hodoscopes

#### 3.1 Existing HHs

Figs. 10, 11, 12, 13, 14.

Horizontal dimension of HH is 1307 mm. HH consists of 16 horizontal slabs separated by 1 mm gaps.

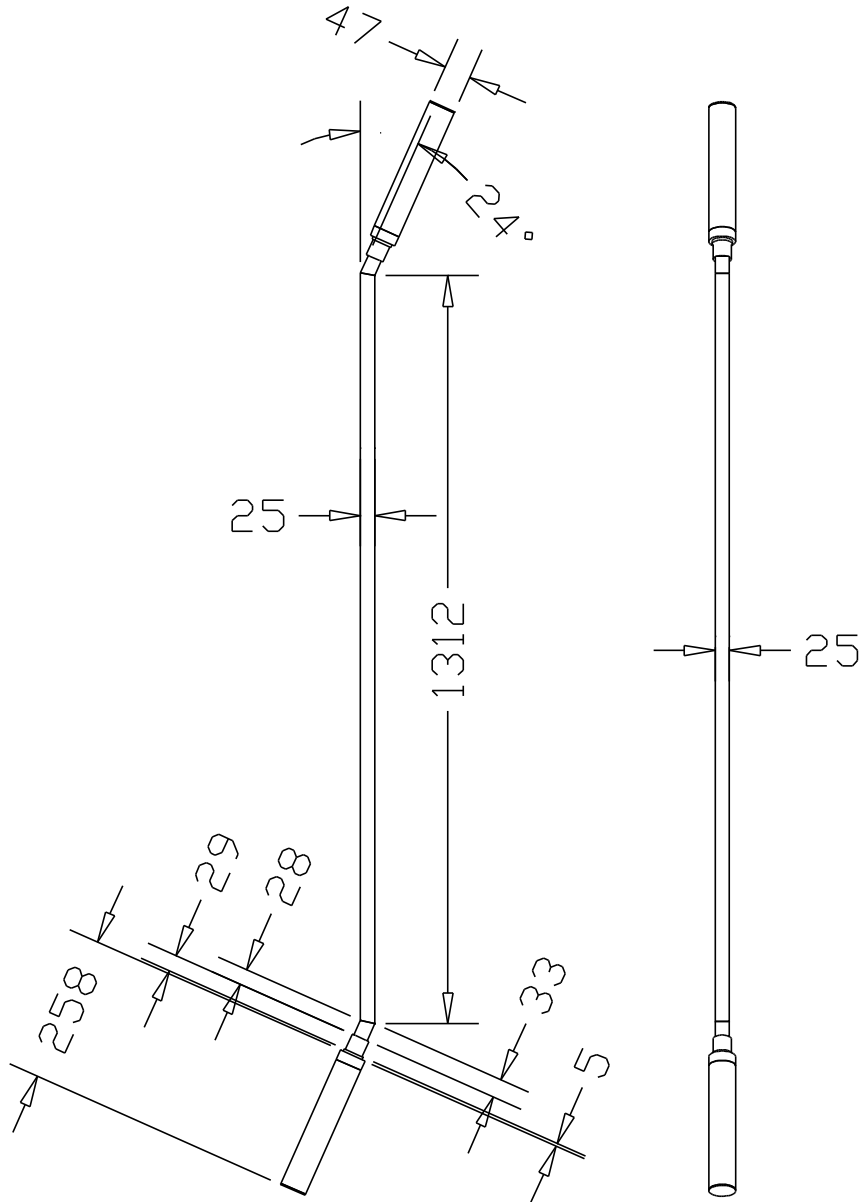

Figure 10: Existing HH: scintillator and PMs.

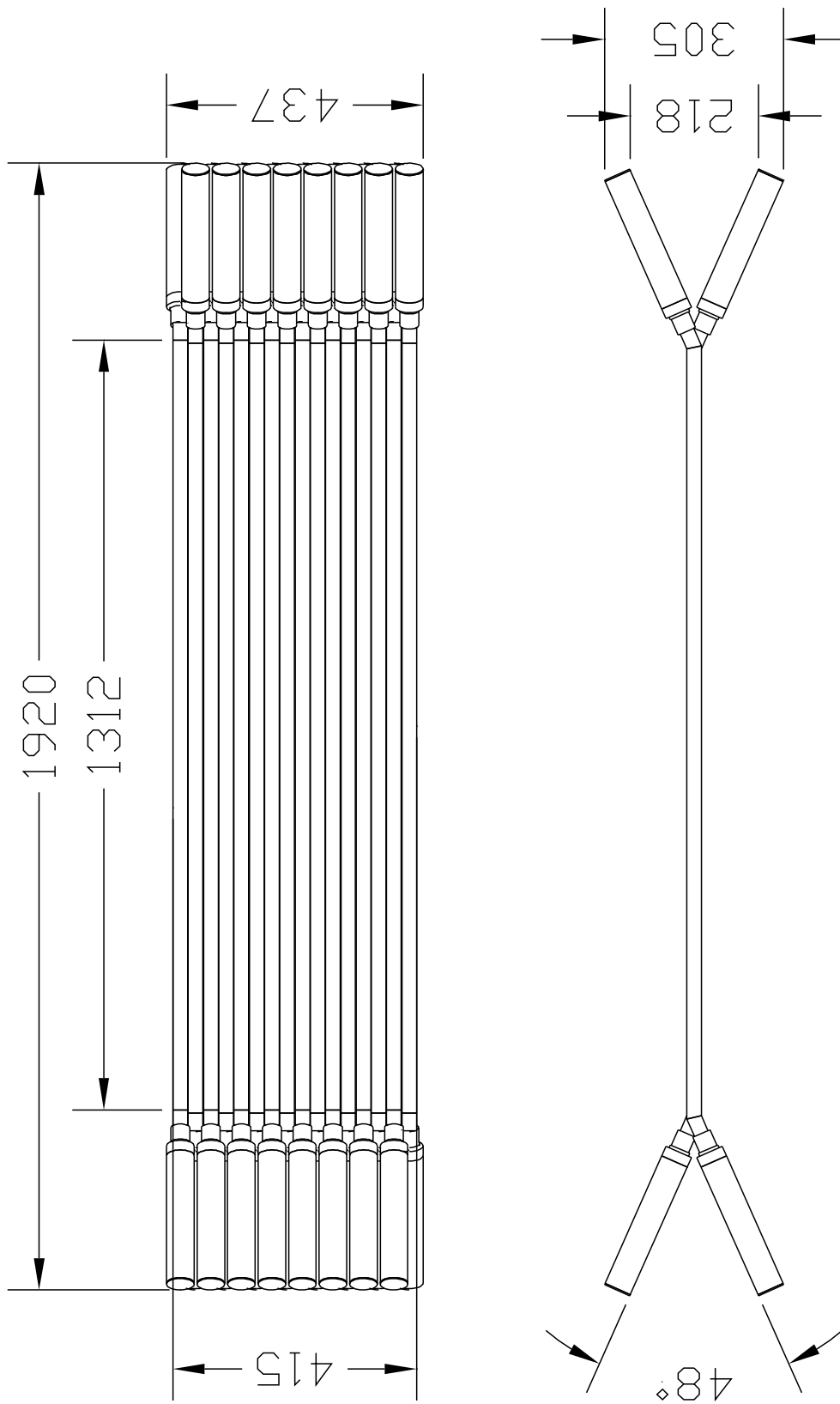

Figure 11: *Existing HH: scintillators and PMs.*

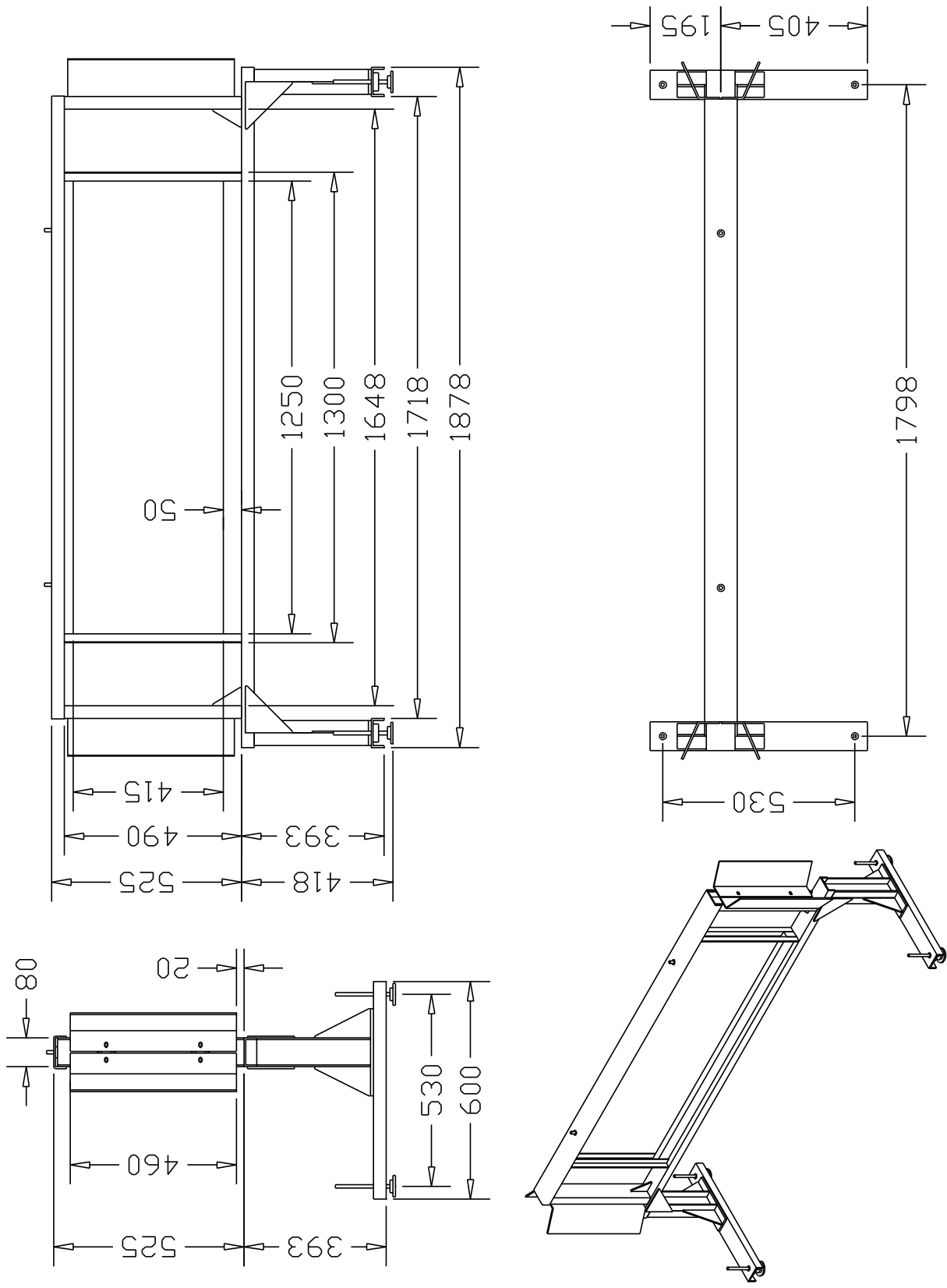

Figure 12: Existing HH: support.



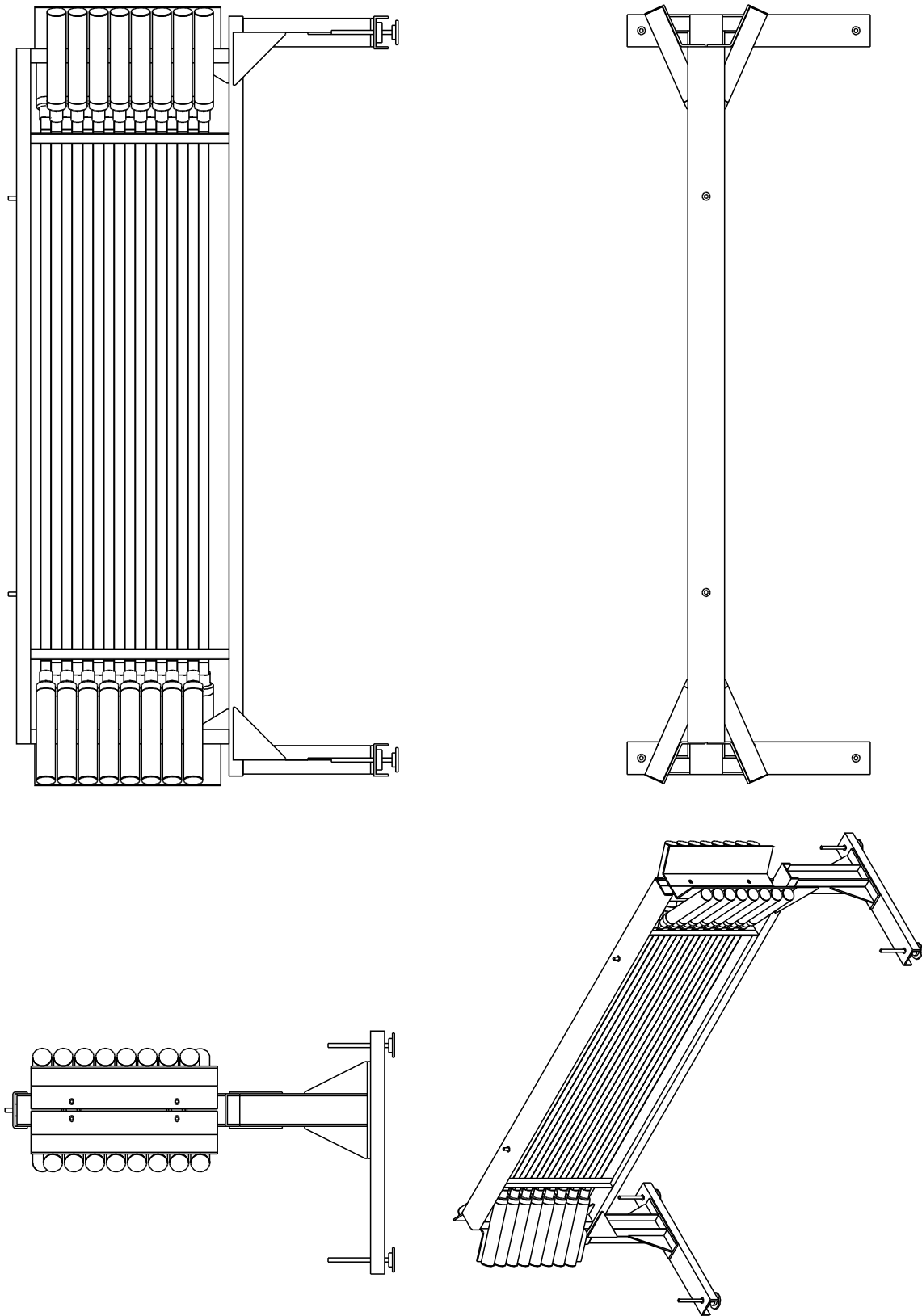

Figure 13: *Existing HH.*

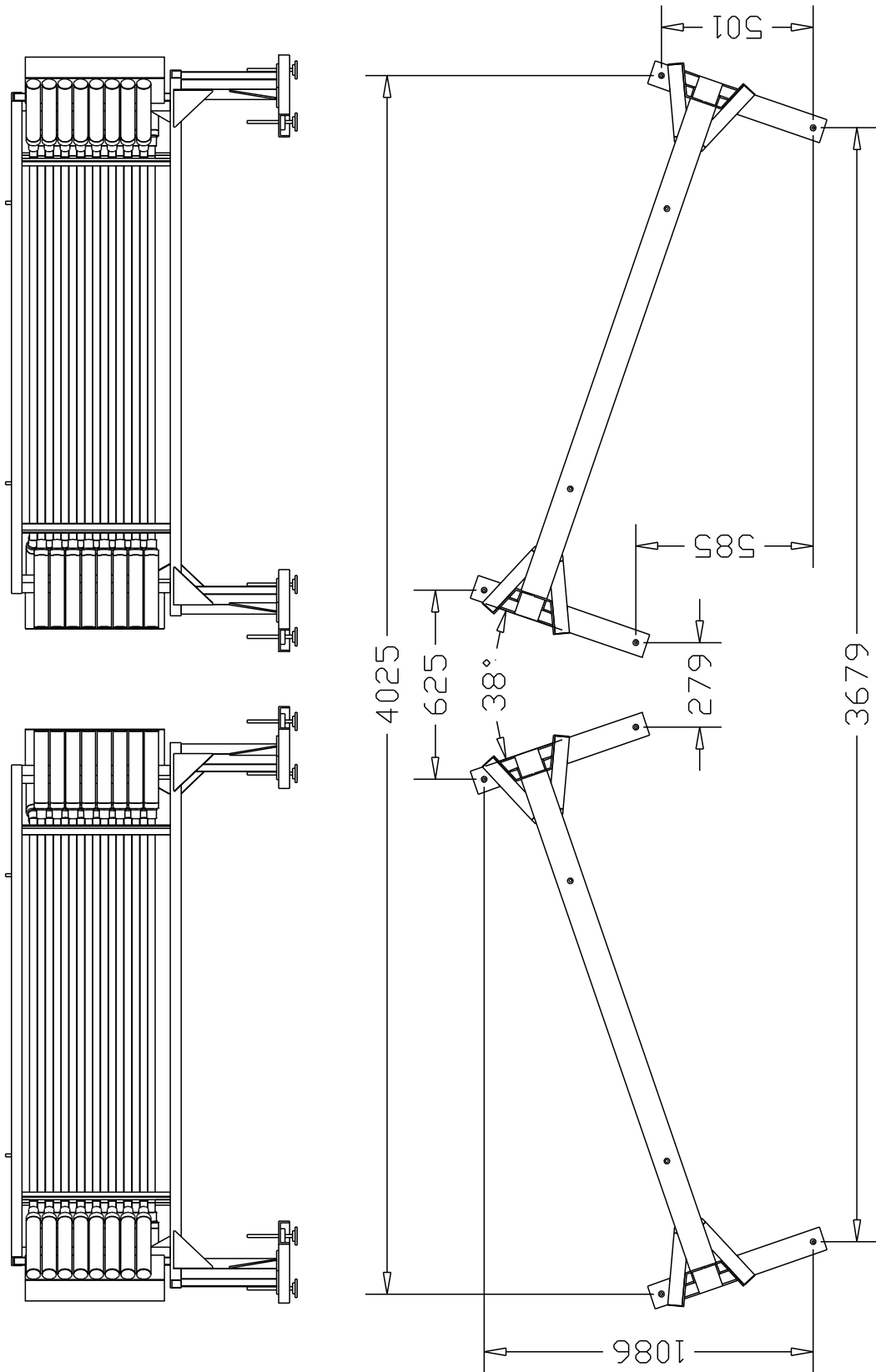

Figure 14: *Existing HHs.*

### 3.2 New HHs

Figs. 15, 16, 17, 18, 19.

If we enlarge HH slabs by 200 mm (180 mm) it will be enough for  $A_{\pi K}$  detection without losses when  $\pi$  and  $K$  are detected by DC.

The simplest way to modify the HH support is to cut the frame in the centre and to weld spacers to it. In addition a small cut should be made at the bottom of the support.

In the new HHs the inward PM housings are separated by 144 mm. So it is necessary to find out how to to repaire PMs and how to connect HF and HV cables to the PMs.

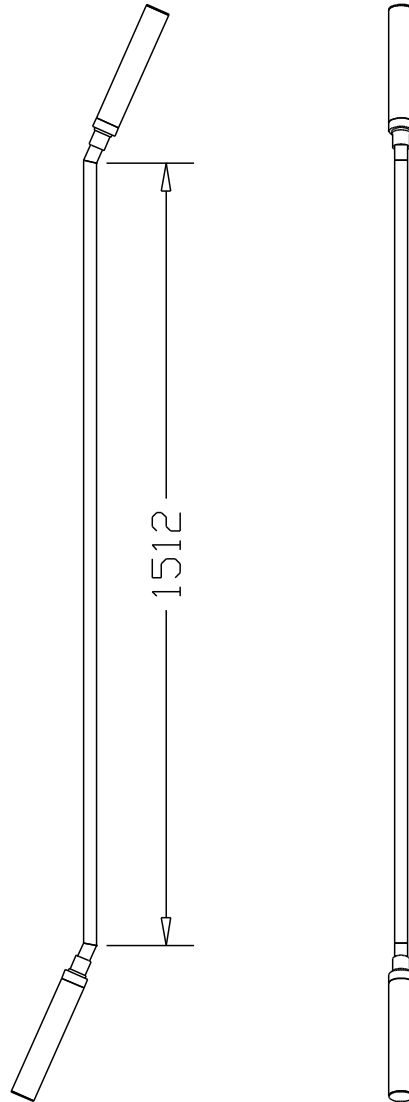

Figure 15: *New HH: scintillator and PMs.*

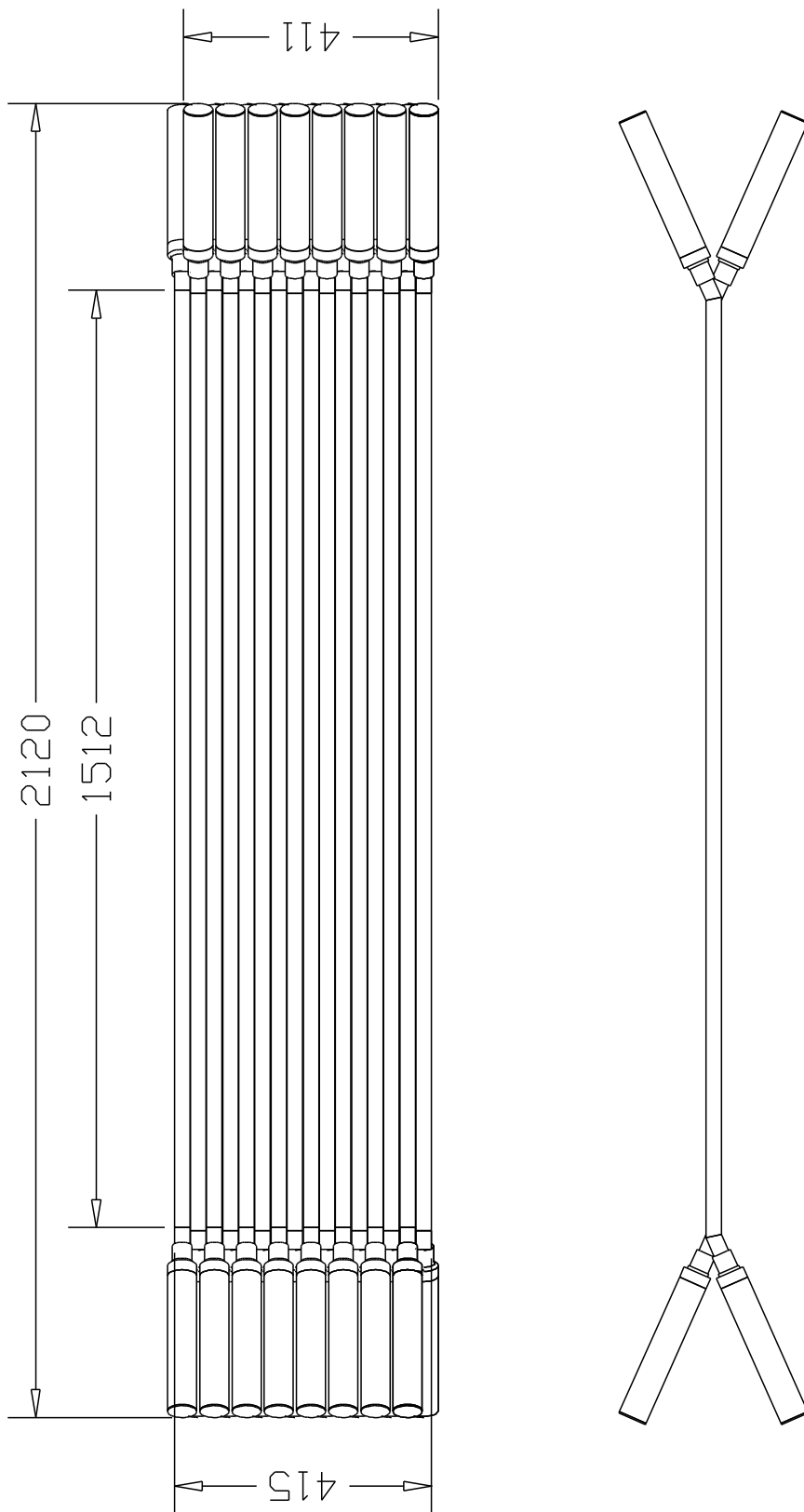

Figure 16: *New HH: scintillators and PMs.*

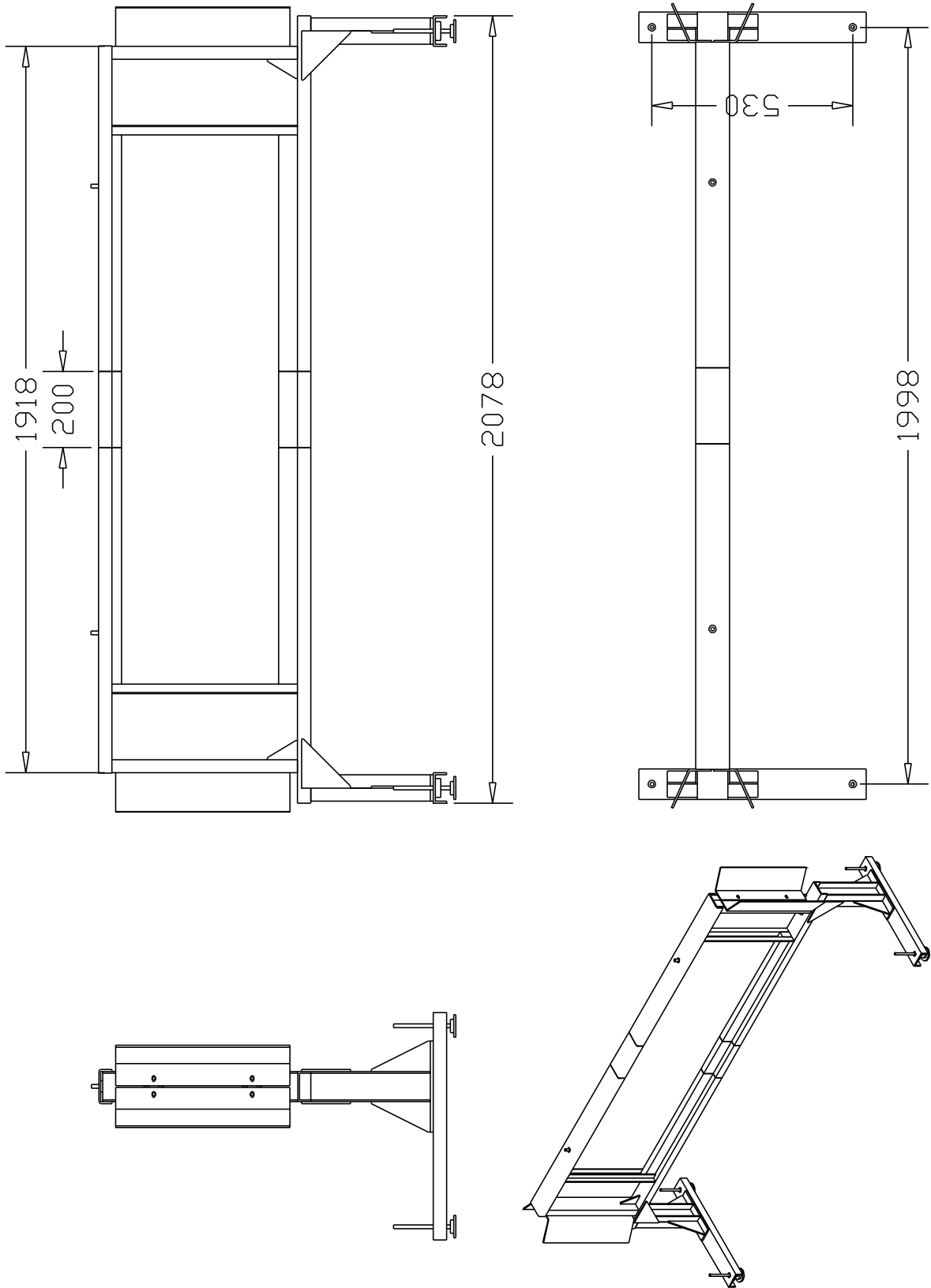

Figure 17: *New HH: support.*

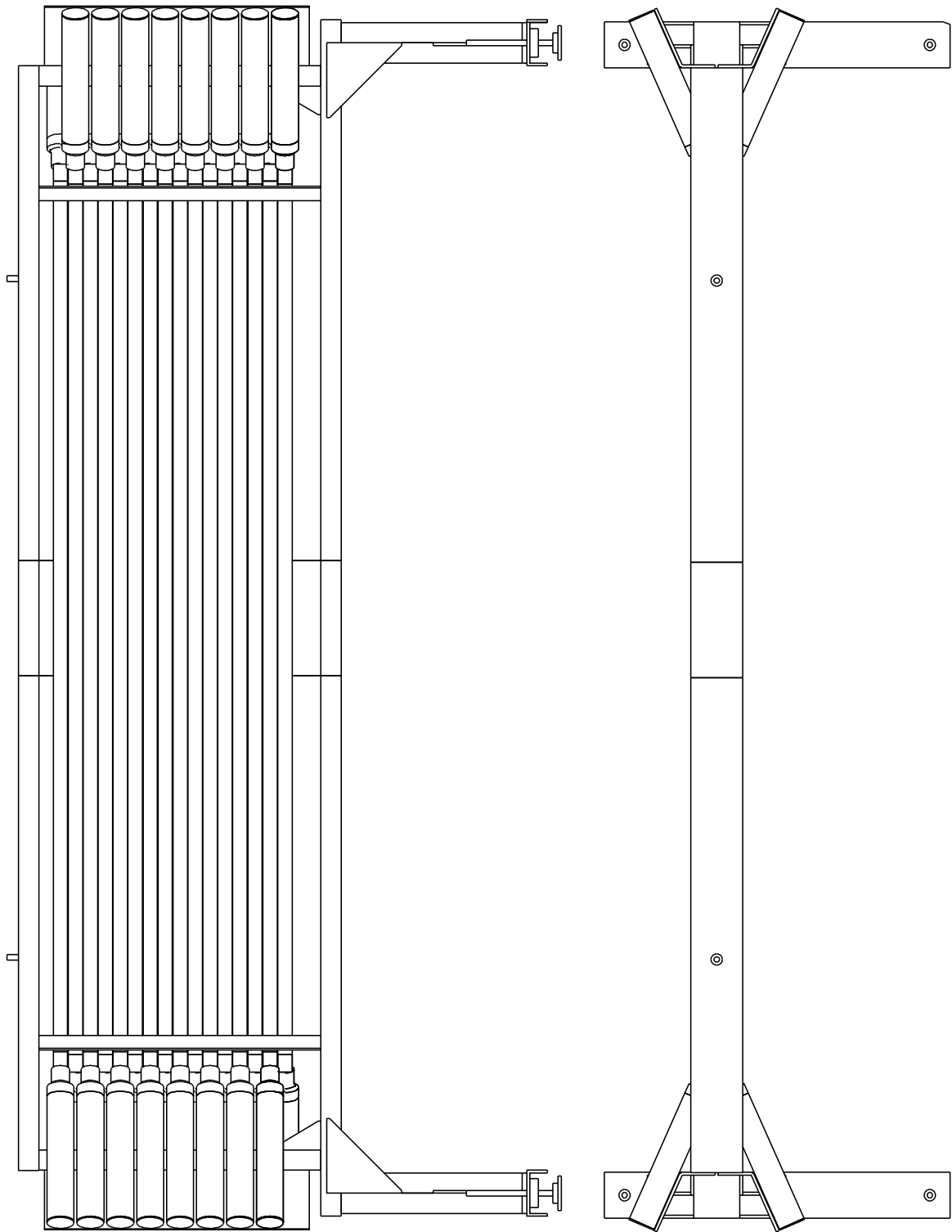

Figure 18: *New HH.*

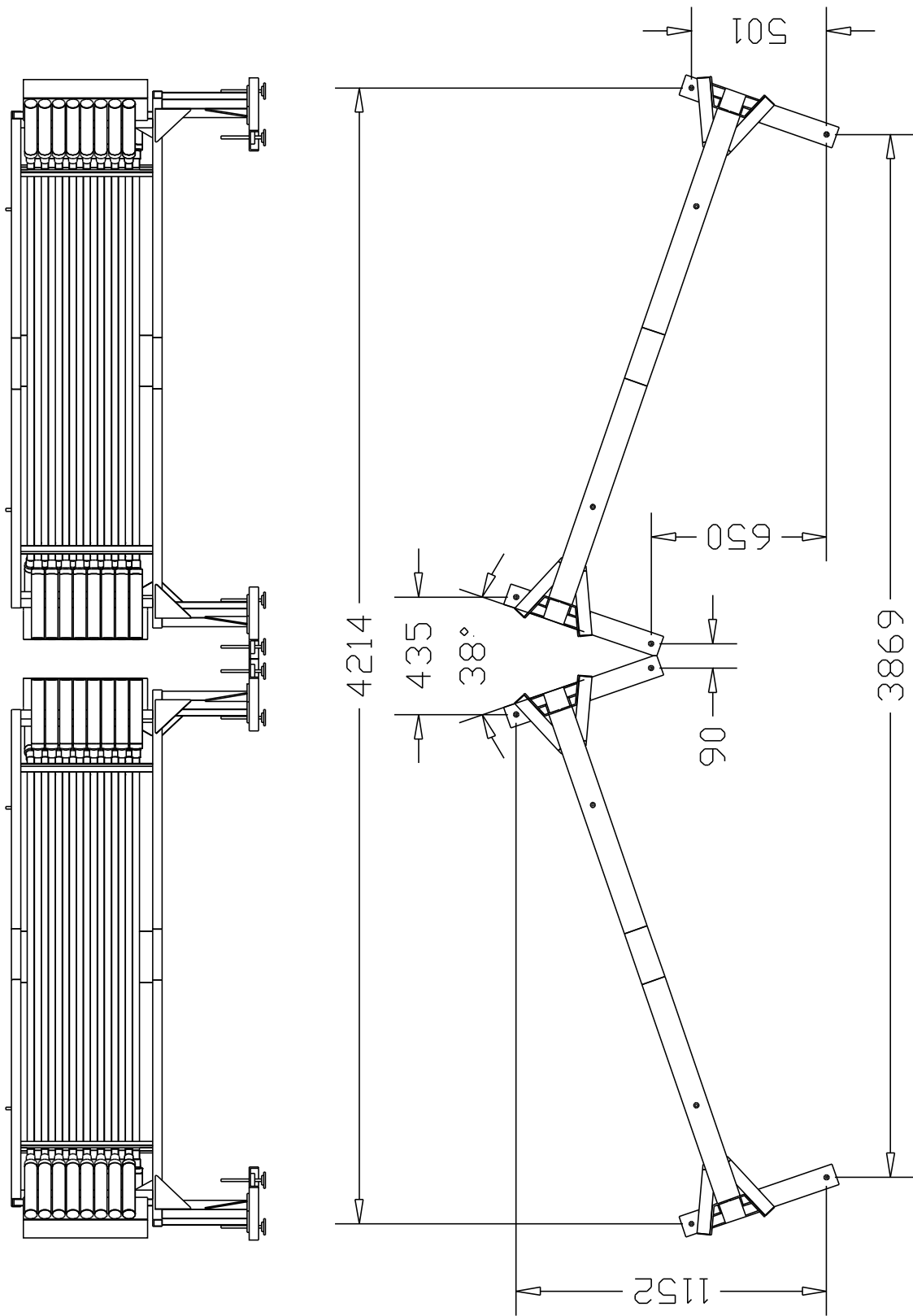

Figure 19: *New HHs.*

## 4 Preshowers

### 4.1 Existing PR

Figs. 20, 21, 22, 23, 24, 25, 26.

Horizontal dimension of PR is 2800 mm. PR consists of 8 scintillation slabs of 350 mm in width practically without gaps.

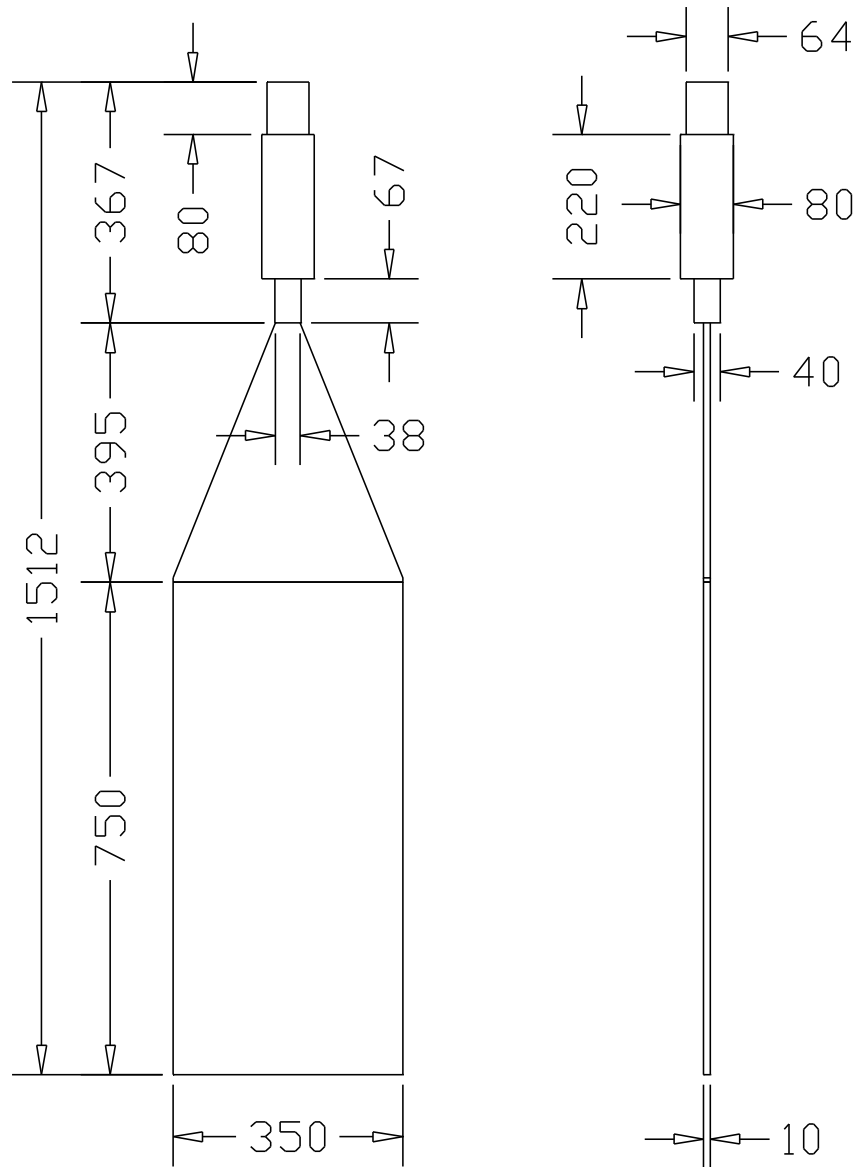

Figure 20: *Existing PR: scintillator and PM.*



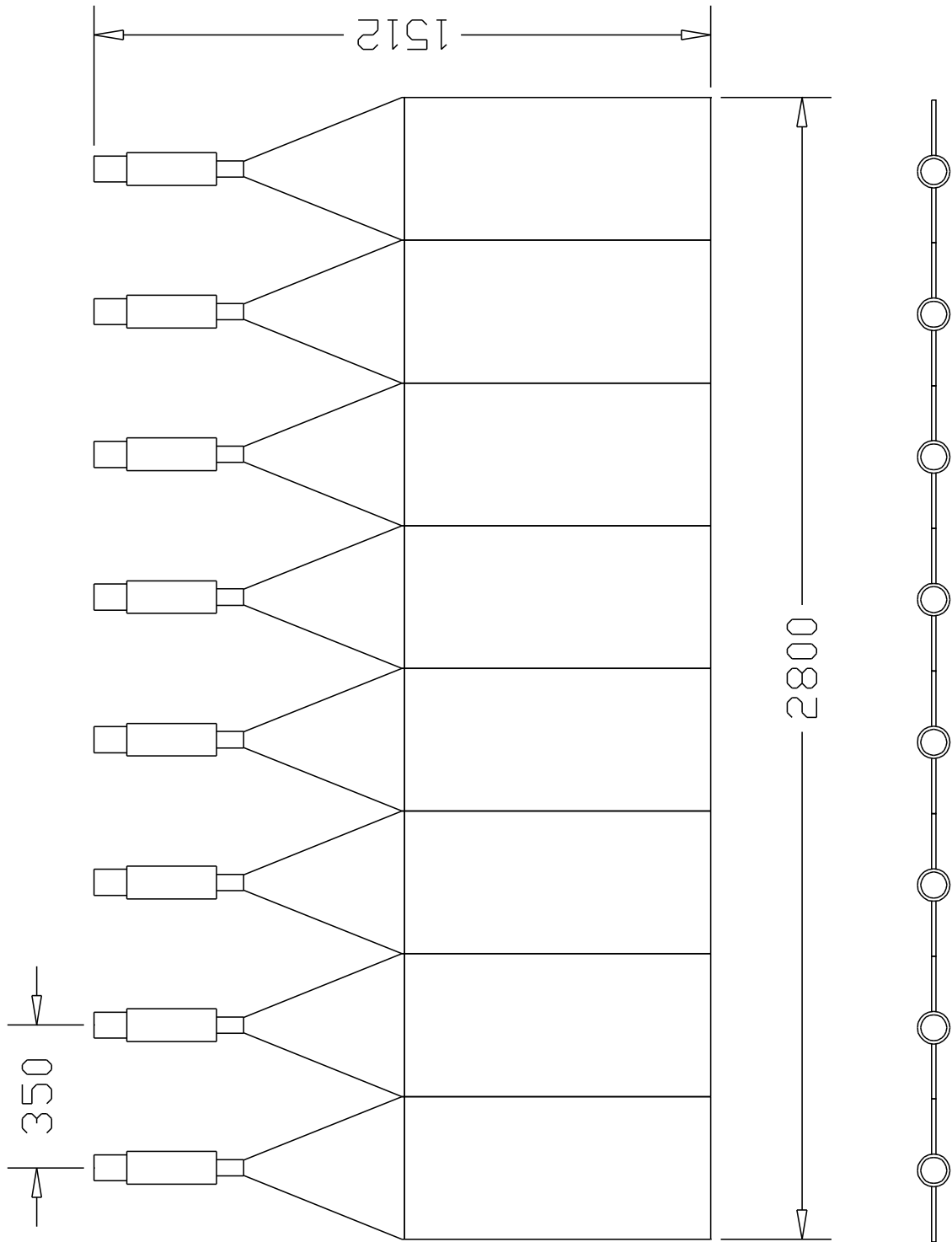

Figure 21: *Existing PR: scintillators and PMs.*

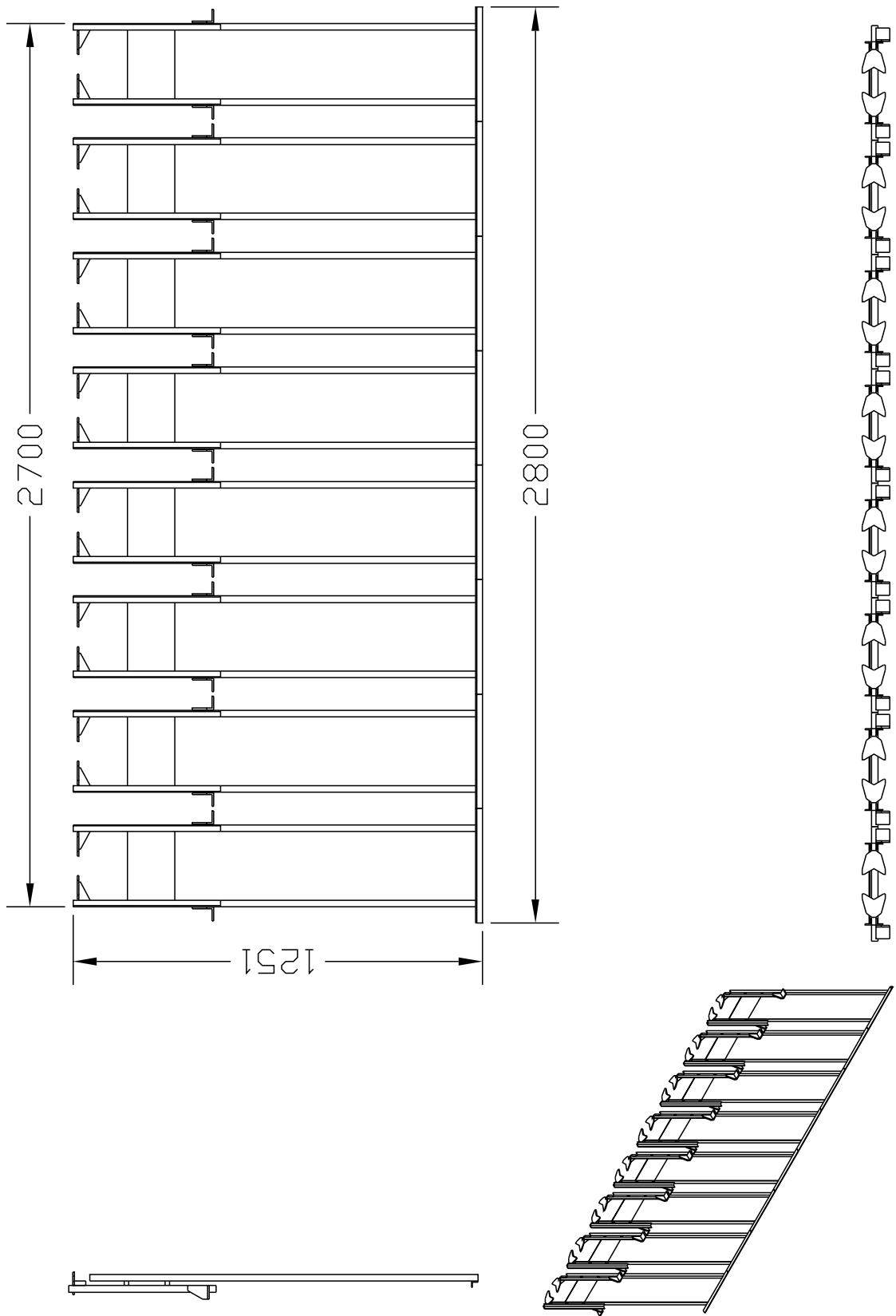

Figure 22: *Existing PR: support for scintillators and PMs.*

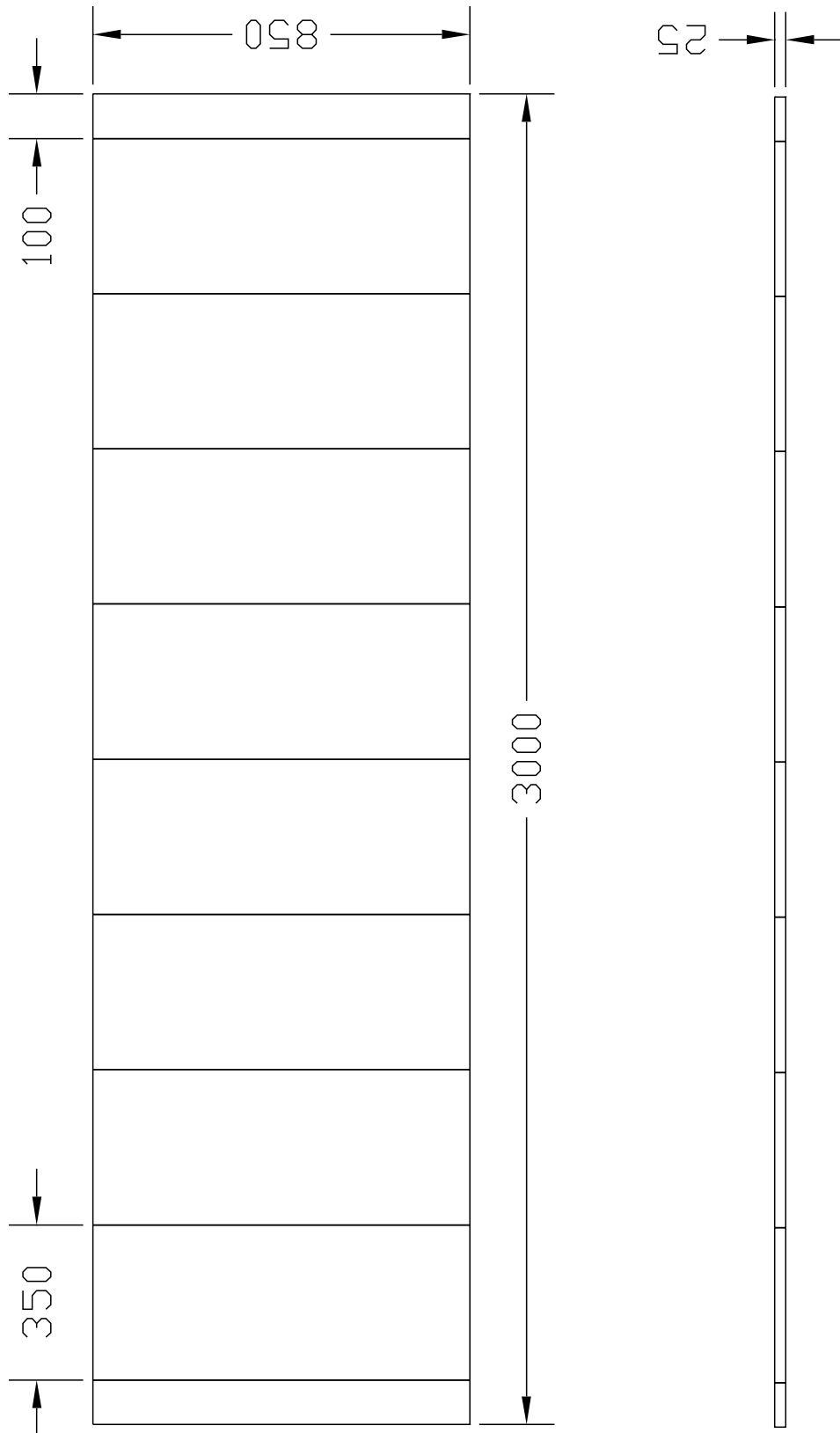

Figure 23: Existing PR: lead.

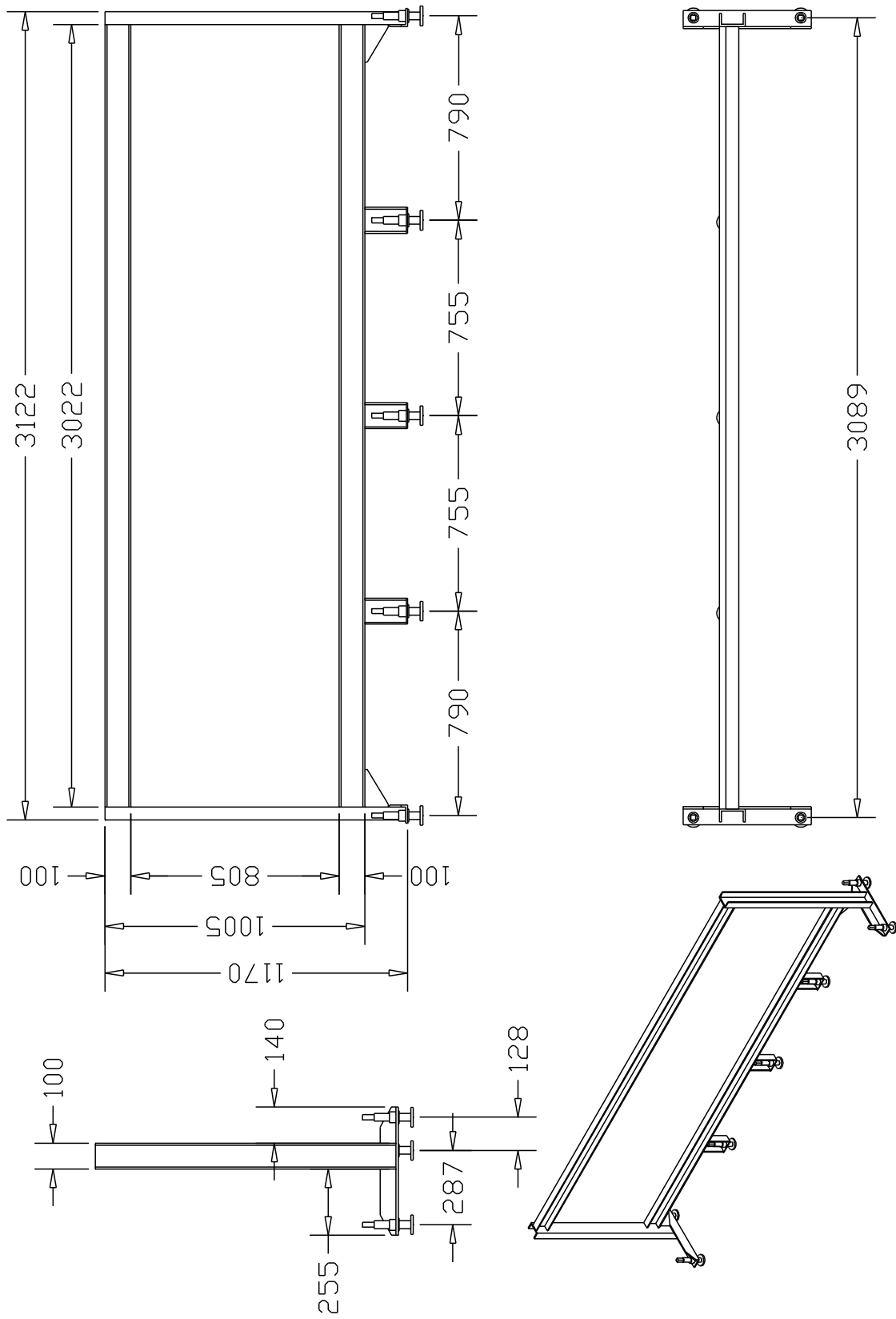

Figure 24: Existing PR: support.

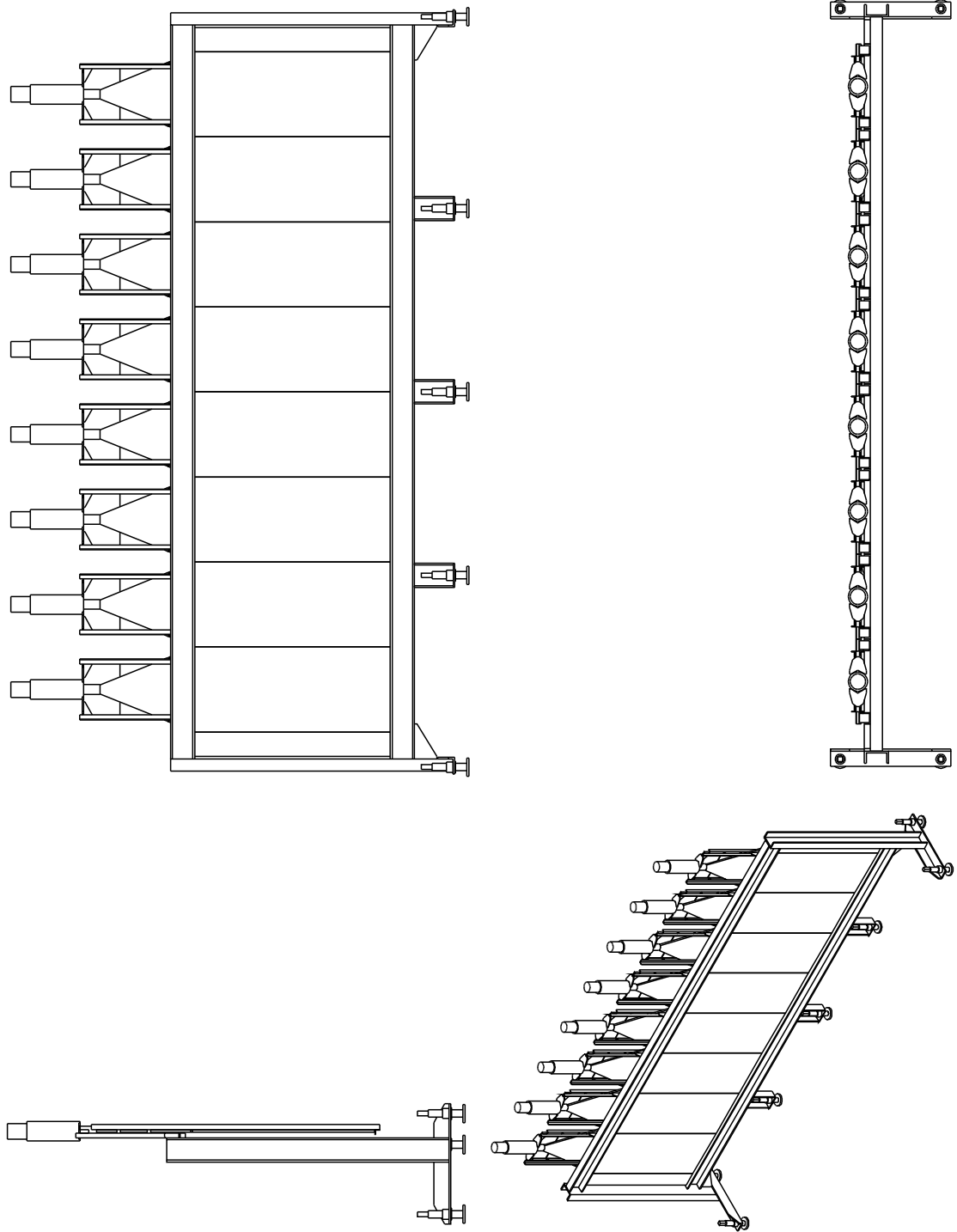

Figure 25: *Existing PR.*

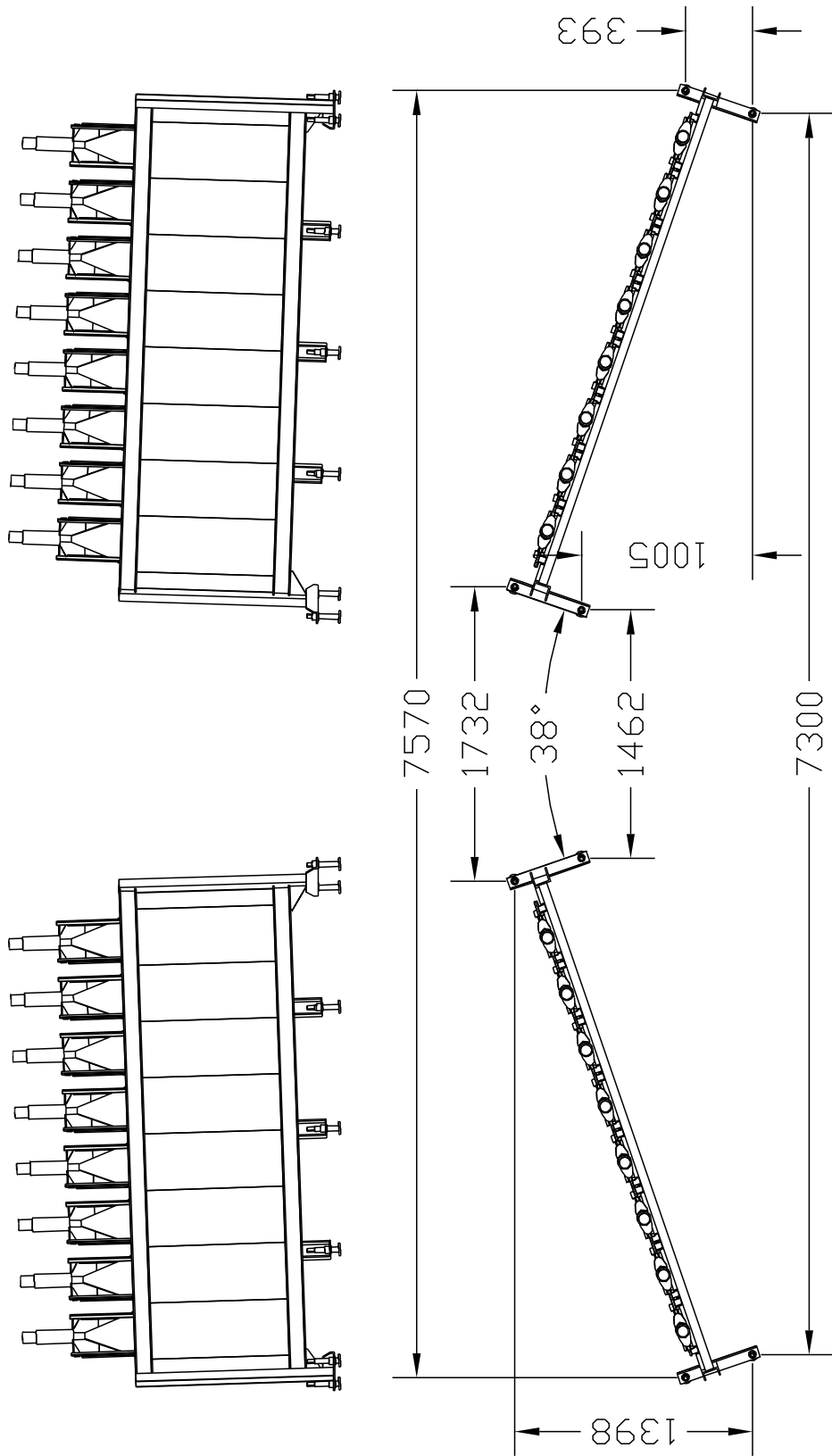

Figure 26: Existing PRs.

## 4.2 New PR

Figs. 27, 28, 29.

If we add two slabs of 350 mm in width to the existing PR it will be enough for  $A_{\pi K}$  detection without losses when  $\pi$  and  $K$  are detected by the DCs.

PR modification retains the existing PR without changes. Two PR modules of 350 mm each (4 modules in total) are attached to both sides of the existing PR.

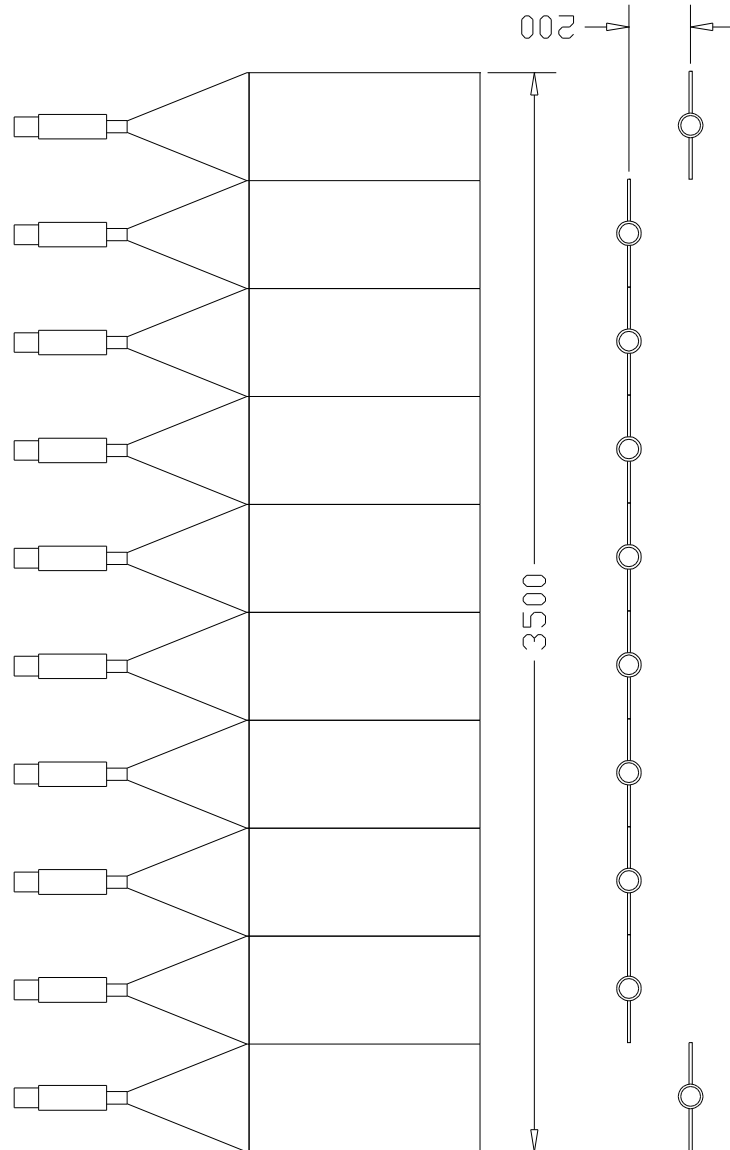

Figure 27: *New PR: scintillators and PMs.*

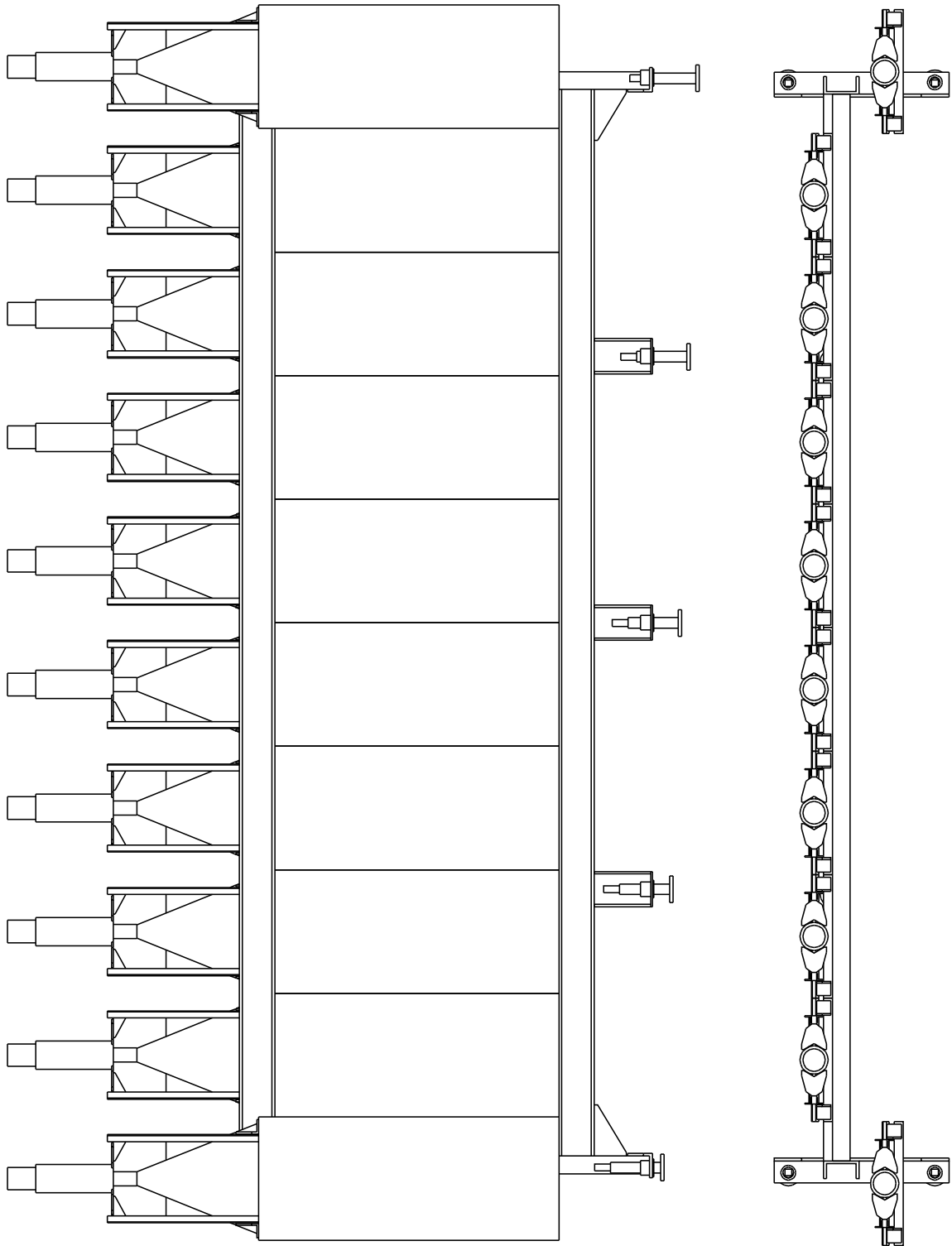

Figure 28: *New PR.*



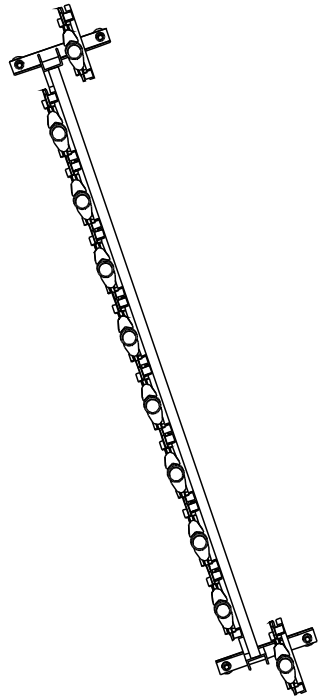
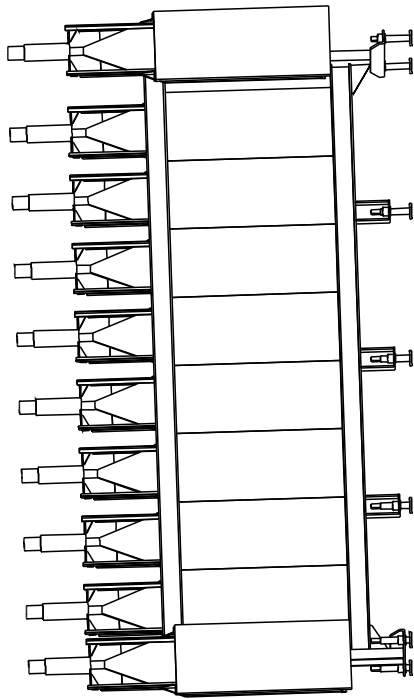
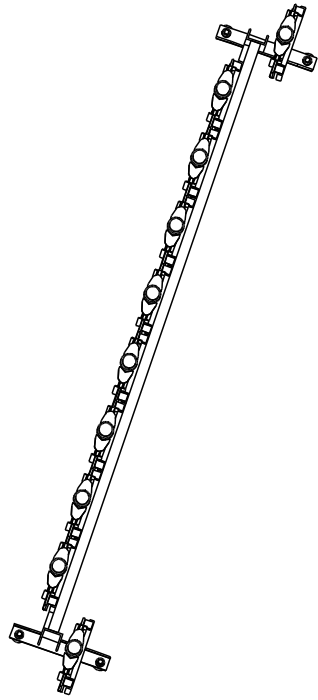
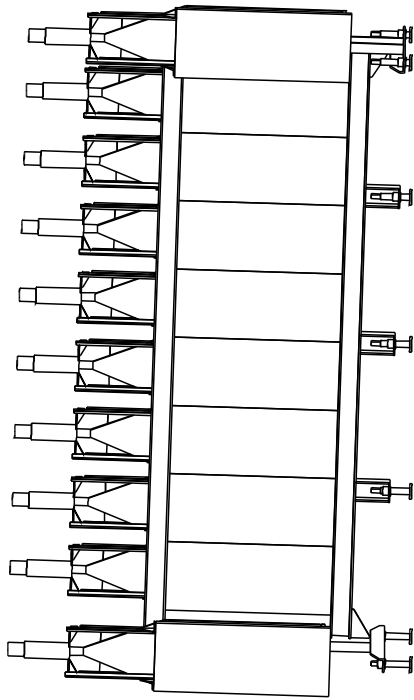

Figure 29: *New PRs.*